



Control System Design for Grid Interconnection and Power Control with Hybrid Fuzzy Controller

TALADA SANTHOSH

M.Tech Student Scholar

Department of EEE

Visakha Institute of Engineering & Technology, Narava

Visakhapatnam (Dt), A.P, India.

L.MURALI MOHAN

Assistant Professor

Department of EEE

Visakha Institute of Engineering & Technology, Narava

Visakhapatnam (Dt), A.P, India.

Dr.B.SRINIVASA RAO

Professor & HOD

Department of EEE

Visakha Institute of Engineering & Technology, Narava

Visakhapatnam (Dt), A.P, India.

Abstract- The penetration of renewable energy in modern power system, Microgrid has become a popular application worldwide. In this concept bidirectional converters for AC and DC hybrid Microgrid application are proposed as an efficient interface. To reach the goal of bidirectional power conversion, both rectifier and inverter modes are analyzed. In order to achieve high performance operation and single-phase bi-directional inverter with dc-bus voltage regulation and power compensation in dc-Microgrid applications. This concept proposes a control design methodology for a multi functional single-phase bidirectional PWM converter in renewable energy systems. There is a generic current loop for different modes of operation to ease the transition between different modes, including stand-alone inverter mode, grid-tied inverter mode, ac voltage regulation is of importance because of the sensitive loads In dc-Microgrid applications, a power distribution system requires a bi-directional inverter to control the power flow between dc bus and ac grid, and to regulate the dc bus to a certain range of voltages, in which dc load may change abruptly. This will result in high dc-bus voltage variations; the bi-directional inverter can shift its current commands according to the specified power factor at ac grid side. Parallel-connected bidirectional converters for AC and DC hybrid Microgrid application are proposed as an efficient interface. To reach the goal of bidirectional power conversion, both rectifier and inverter modes are analyzed. The proposed concept can be implemented by hybrid fuzzy controller by using Matlab/Simulink software.

Keywords—Microgrid, Grid-tie Inverter, Voltage control, Automatic power control.

I. INTRODUCTION

Micro grids are the networks comprising of various generators, storage devices, and controllable loads that can operate either grid connected or islanded mode as a controlled entity. Suitable micro-grid control strategy design is the key for stability of the microgrid under different operation mode, especially when changing from the grid connected operation to the islanding operation. Operation of micro-grid in grid connected mode demands control of power flow from micro-grid to utility grid. Photovoltaic generation on DC bus is highly intermittent. Therefore, it is required to regulate the power flow between DC bus and AC bus which is achieved by phase angle control. Voltage and frequency control formulate the control system for synchronization. This paper describes design, simulation and practical implementation of the control strategy for grid tie inverter.

II. GRID TIE-INVERTER CONTROL PROBLEM

Synchronization of inverter with grid requires inverter frequency to be equal to that of grid. Grid has almost constant frequency, however difference in frequency of inverter output and grid results in high power imbalance. Phase difference is key factor which determines the active and reactive power flow to and from grid [1]. A varying phase difference can cause varying power flow in the circuit. With inverter frequency at 49 Hz and grid frequency at 50 Hz the variations in power flow can be seen in fig 1.[6]

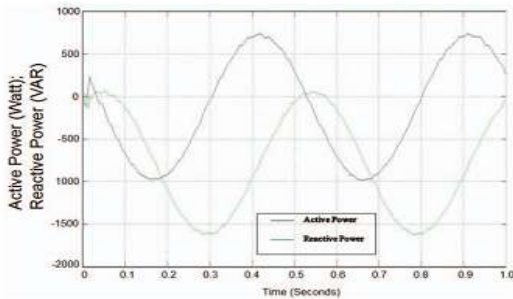

Fig. 1: Power flow due to frequency variations

Voltage of inverter governs the reactive power flow and needs to be regulated. Difference in inverter terminal voltage and grid voltage results in reactive power flow[1]. Control System is required to maintain required voltage and frequency in islanded condition. Control System needs to be robust and have quick response time. Delays in response time can lead to failure of synchronization of inverter with grid and lead to varying power flow and can damage inverter power circuit [2].

III. PROPOSED SOLUTION

To deal with the problem statement mentioned above, various control strategies are incorporated.

A. Power Control System To throw constant power into the grid, the capacitor voltage must be maintained constant. As the power generated on DC bus increases capacitor gets over-charged. Voltage of capacitor is compared with a reference value and using PID control system the power angle of inverter is changed to control the power flow into the grid (fig. 2). The capacitor voltage is maintained at such a value so as to reduce reactive power demand of inverter.

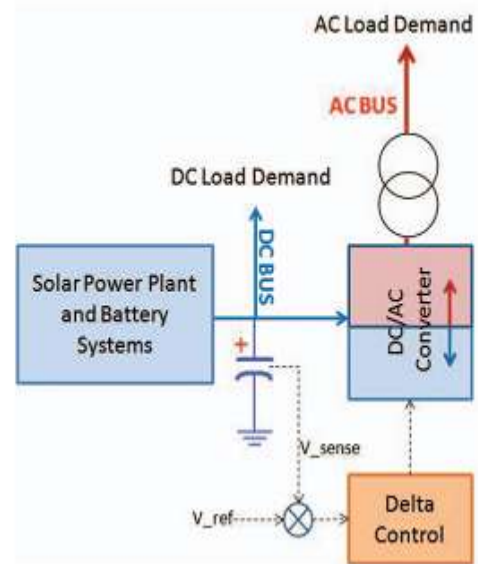

Fig. 2: Control System for Power flow

Discrete PID control [3] is applied for active and reactive power control. PID control is implemented to maintain the voltage of capacitor same as that of reference voltage. The power transfer from DC side to AC side is governed by phase angle (power angle), given by equation

$$P_{active} = \frac{EV \sin(\delta)}{X}$$

As the Capacitor voltage increases phase angle is increased to alter the power flow from Inverter to Grid.

B. Frequency Control System The feedback obtained from the grid is stepped down to 5 Volts. The grid waveform is converted to square wave using sine to square wave converter. Obtained square wave is used to measure frequency of the grid. The square wave acts as input to external interrupt hardware of micro-controller which measures the frequency of interrupts received (fig. 3). The frequency of inverter output is related to frequency of SPWM used to drive inverter bridges. Thus the frequency of inverter can be changed to frequency of grid measured using external interrupt hardware and frequency of grid is synchronized with frequency of inverter. Frequency control system has improved response time due to analog external interrupt hardware.

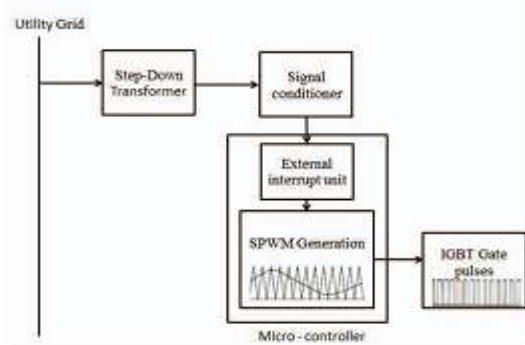

Fig.3: Frequency control system.

C. Phase Control System Phase control system maintains the phase difference between inverter generated wave and grid voltage wave constant. The sinusoidal wave of grid is stepped down using a transformer and converted to corresponding square wave. Square wave acts as an external interrupt to processor/ microcontroller generating SPWM. Phase of generated SPWM can be adjusted according to the external interrupt received and power angle predefined as per power flow required. PID controller[3] is used to give perfect matching of phase angle after the filter and phase angle of grid wave. The PID controller is necessary because the filter gives some additional phase shift to inverter generated voltage wave.

D. Voltage Control System Micro-Grid has limited generation and in islanded mode as the load on inverter increases the voltage regulation of inverter increases. The Voltage of inverter falls below rated terminal voltage. Voltage Control System involves regulation of terminal voltage. It involves feedback from inverter terminal which is given to PID control which changes the modulation index of SPWM waveforms and alters the terminal voltage of inverter.

E. Design of Discrete PID Controller

The Transfer function of discrete PID Controller[5] is shown in fig 4.

$$\frac{U[z]}{E[z]} = Kp + Ki * \frac{Ts}{2} * \frac{z+1}{z-1} + Kd * \frac{z-1}{zTs} \tag{1}$$

$$\frac{U[z]}{E[z]} = \frac{(Kp + Ki * \frac{Ts}{2} + \frac{Kd}{Ts})z^2 + (-Kp + Ki * \frac{Ts}{2} + \frac{Kd}{Ts})z + \frac{Kd}{s}}{z^2 - z} \tag{2}$$

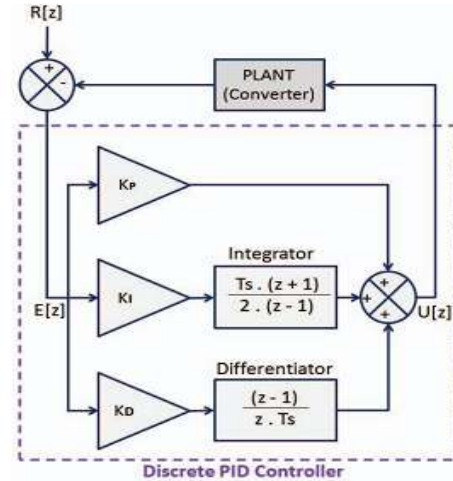

Fig. 4: PID Control System for Power Angle Control

$$U[z] = z^{-1}U[z] + aE[z] + bz^{-1}E[z] + cz^{-2}E[z] \tag{3}$$

$$u[k] = u[k-1] + ae[k] + be[k-1] + ce[k-2] \tag{4}$$

$$a = Kp + Ki * \frac{Ts}{2} + \frac{Kd}{s} \tag{5}$$

$$b = -Kp + Ki * \frac{Ts}{2} - \frac{2Kd}{s} \tag{6}$$

$$c = \frac{Kd}{Ts} \tag{7}$$

Ts = Sampling time of the discrete system

Kp = Proportional gain

KI = Integral gain

KD = Differential gain

U[z] = input to the plant

R[z] = reference to controller

E[z] = error sequence [4]

Trade-off between overshoot and settling time is achieved by proper tuning of Kp, Ki, Kd values used above. Discrete PID controller developed maintains the capacitor voltage to the reference value and controls the reactive power flow from the inverter by variations in power angle of inverter. Active Power is proportional to sine of the power angle. PID controller



works best in linear range. Therefore saturation block is introduced after the PID controller to limit the output from $-\pi/2$ to $\pi/2$. The DC Bus voltage of microgrid is 48V which is reference voltage for PID controller.

HYBRID FUZZY:

This paper investigates two fuzzy logic controllers that use simplified design schemes. Fuzzy logic PD and PI controllers are effective for many control problems but lack the advantages of the fuzzy controller. Design methodologies are in their infancy and still somewhat intuitive. Fuzzy controllers use a rule base to describe relationships between the input variables. Implementation of a detailed rule base increases in complexity as the number of input variables grow and the ranges of operation for the variables become more defined. We propose a hybrid fuzzy controller which takes advantage of the properties of the fuzzy PI and PD controllers and a second method which adds the fuzzy PD control action to the integral control action.

The effectiveness of the two PID fuzzy controller implementations, PD and PI fuzzy controllers have the same design disadvantages as their classical counterparts. Therefore, in some cases a fuzzy PID controller maybe required. The fuzzy PID controller entails a large rule base which presents design and implementation problems. First, a reduced rule fuzzy PID scheme was implemented to take advantage of both PD and PI control actions. Some further research is required for the process of switching between the control actions. The second fuzzy PID control scheme used only the PD portion with an integral term added to eliminate steady-state error. Results from simulations of both control schemes demonstrate the effectiveness of the PID controller

IV. SIMULATIONS AND RESULTS

The Grid-tie inverter was simulated in MATLAB. The SPWM generator block has input of phase angle (power angle) and modulation index for the SPWM waves. The terminals DC4 and DC4 are connected to PV system. The terminals AC1, AC3, AC5 are AC output terminals. The LCL filter is connected between inverter and power measurement unit. The LCL filter filters the output voltage waveform of inverter. The PID controller is discrete type, and

controls the phase angle so as to maintain DC link voltage constant. The model is simulated in discrete mode. Ode 45 equation solver is used and the sampling time is of 5e-6 sec.

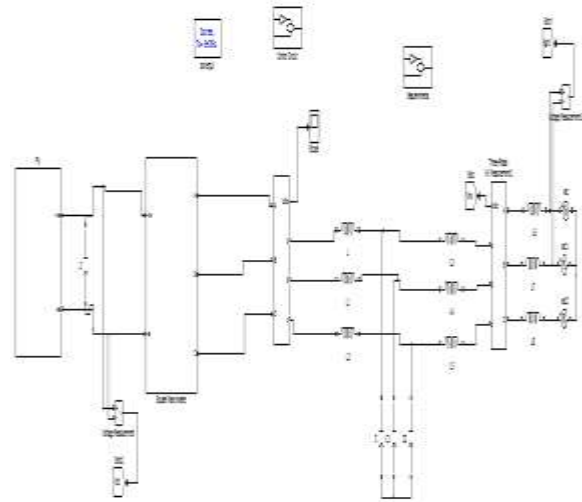

Fig. 5: Simulated Control System DC-AC Converter

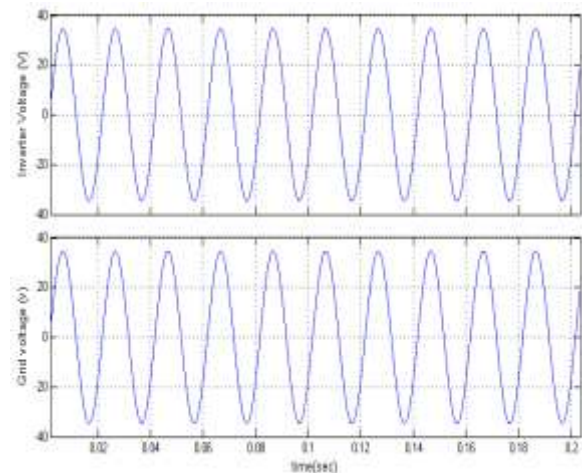

Fig 6 simulation wave form of frequency synchronization.

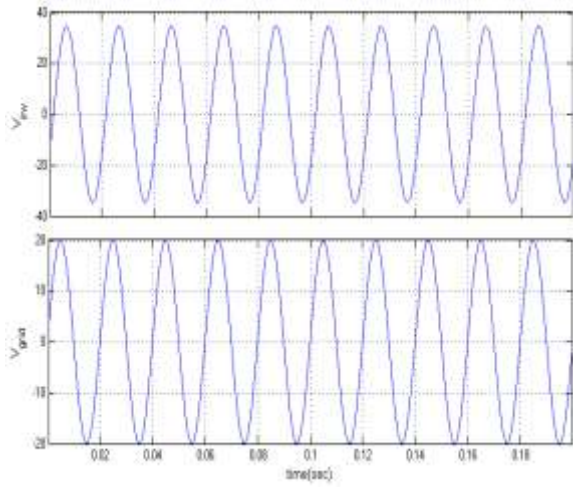

Fig.7. simulation waveform of Phase offset given to inverter w.r.t grid.

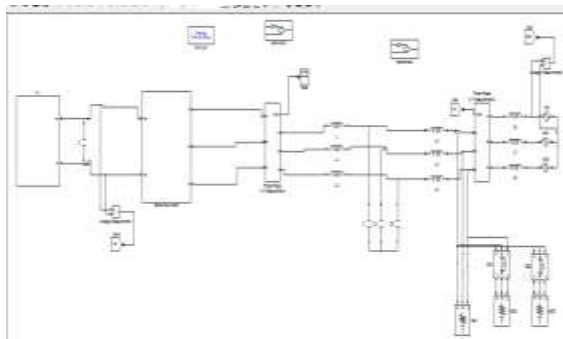

Fig 8 Simulated Control System for Grid Connected DC-AC Converter

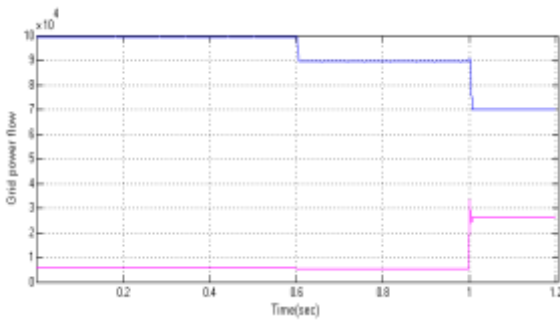

Fig 9 Manual control of active power transfer

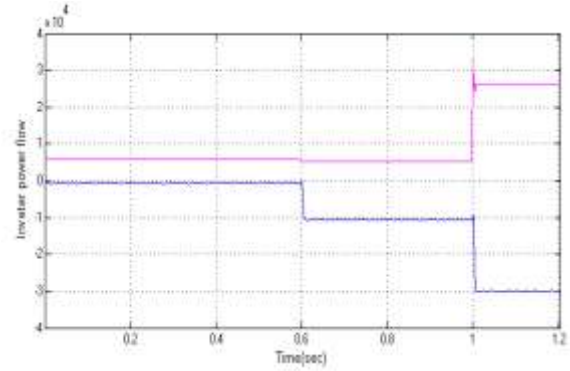

Fig 10 Automatic control of active power and DC link voltage

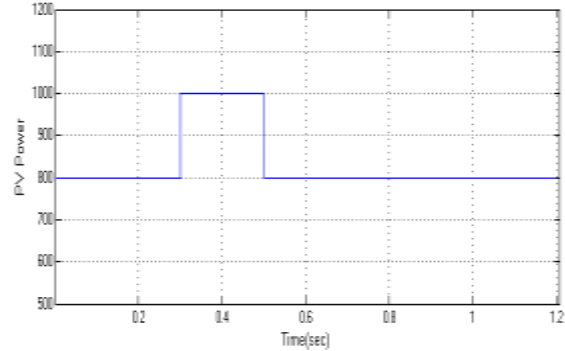

Fig 11 simulation wave form of Power generation by PV

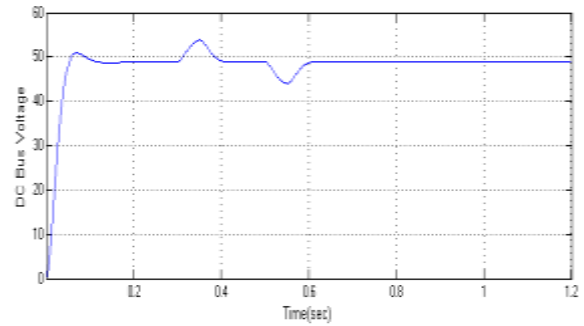

Fig 12 simulation wave form of DC link voltage

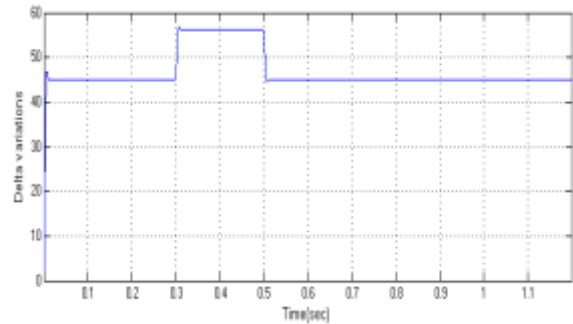

Fig.13. simulation waveform of Delta Variation.

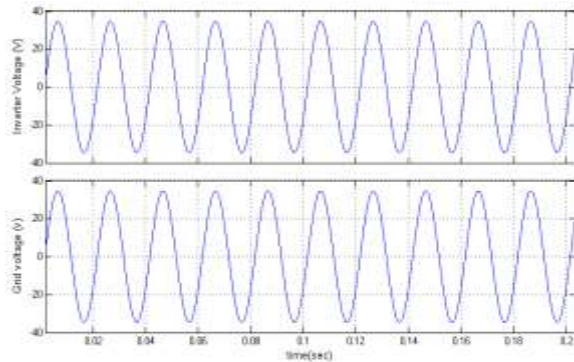

Fig 14 simulation wave form of input and grid voltage with hybrid fuzzy controller

VII. CONCLUSION

This paper gives description about implementation of hybrid fuzzy control system for grid-tie inverter. The control system developed has better response time due to external interrupt hardware. The frequency control system and phase control system keep the inverter in exact synchronization and provide desirable phase angle between inverter voltage wave and grid voltage wave. Control system is able to regulate the power flow into AC bus and maintain the DC link voltage constant through control action. Power flow variations due to increase in generation on DC bus causes fluctuations in DC link capacitor voltage which cannot be restricted beyond certain extent due to limitations of PID control and hybrid fuzzy controller can be implemented.

REFERENCES

- [1] Zia, F.B., Salim, K.M., Venus, S., "Experiment with a locally developed single phase grid tie inverter" *Proc. of IEEE Informatics, Electronics & Vision (ICIEV)*, 2012, Dhaka.
- [2] Sung-Yeul Park, "An easy, simple, and flexible control scheme for a three-phase grid-tie inverter system"
- [3] Ang K.H., Chong G., Li Y., "PID control system analysis, design, and technology" *IEEE Trans. Control Syst. Technol.* 13(4), 559–576 (2005)
- [4] L. A. Serpa, et al., "A Modified Direct Power Control Strategy Allowing the Connection of Three-Phase Inverters to the Grid Through LCL Filters," *IEEE Trans on Industry Applications*, vol. 43, pp. 1388-1400, Sep/Oct. 2007. (Pubitemid 47570239)
- [5] Ibrahim A. El-Sharif, Fathi O. Hareb and Amer R. Zerek, "Design of Discrete time PID controller",